



MGCB1-U110-00

Specification

Part Series	GNSS Receiver Module
Part Number	MGCB1-U110-00
Version	V0.2

Contents

1. Overall	3
2. Feature	3
3. Application	4
4. Pin Configuration and Function	5
4.1 Pin Configuration (Top View).....	5
4.2 Pin Function	5
5. Performance.....	6
5.1 RF performance	6
5.2 Digital performance	6
6. Application	7
6.1 with passive antenna	7
6.2 with active antenna	7
7. Electrical Specification.....	8
7.1 Absolution Rating.....	8
7.2 ESD Rating.....	8
7.3 Recommended Operation Conditions	8
7.4 Power consumption	8
8. Mechanical Specification	9
8.1 Outline Dimensions.....	9
8.2 PCB land pattern dimensions	10
9. Ordering Information.....	11
9.1 Ordering Information	11
10. INPAQ relative and peripheral product	11
11. Manufacturing.....	12
11.1 Reflow Soldering Thermal Profile.....	12
11.2 Thermal profile parameter.....	12
12. Version	13

1. Overall

The MGCB1-U110 series is compact, dual band, multi-constellation GNSS receiver module. The module support L1 and L5 band GNSS. The dual band and multi-system GNSS receiver provides the high precision, visible satellite and fast acquisition time. These key features provide excellent performance on position application.

The MGCB1-U110 series provide fast TTFF time, acquisition time and up to 135 satellite channel. The module integrates low noise amplifier and high rejection filter. These designs will provide high receiver sensitivity and reduce noise interface.

The MGCB1-U110 series is excellent and easy to use in navigation and position application. The package with stamp hole and compact, that is easy to mount on system board.

2. Feature

- L1 and L5 band GNSS receiver
- Support GPS, GLONASS, Galileo, BeiDou, QZSS
- Support Max. 135 channel (L1 75 + L5 60)
- Time to First Fixed (TTFF)
- Max 10Hz update rate
- Integrate low noise amplifier
- Integrate high rejection filter
- Integrate DC blocking in RFin
- Signal voltage supply (3.3V)
- UART interface (1.8V level)
- low power consumption
- ESD protection
- Small and Standard module package (1612)
- Support SMD process
- RoSH/REACH Compliance
- CE/RED Certification (ETSI EN 303 413)

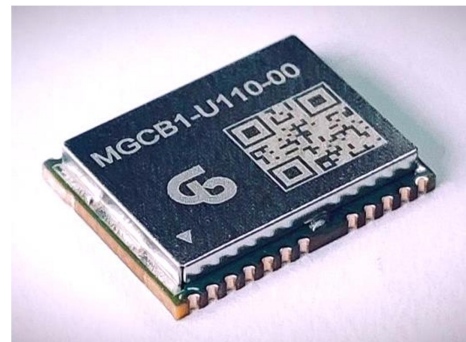

3. Application

- Personal position and navigation
- IoT
- Smart city
- Base station location and alignment

Simplified Schematic and application

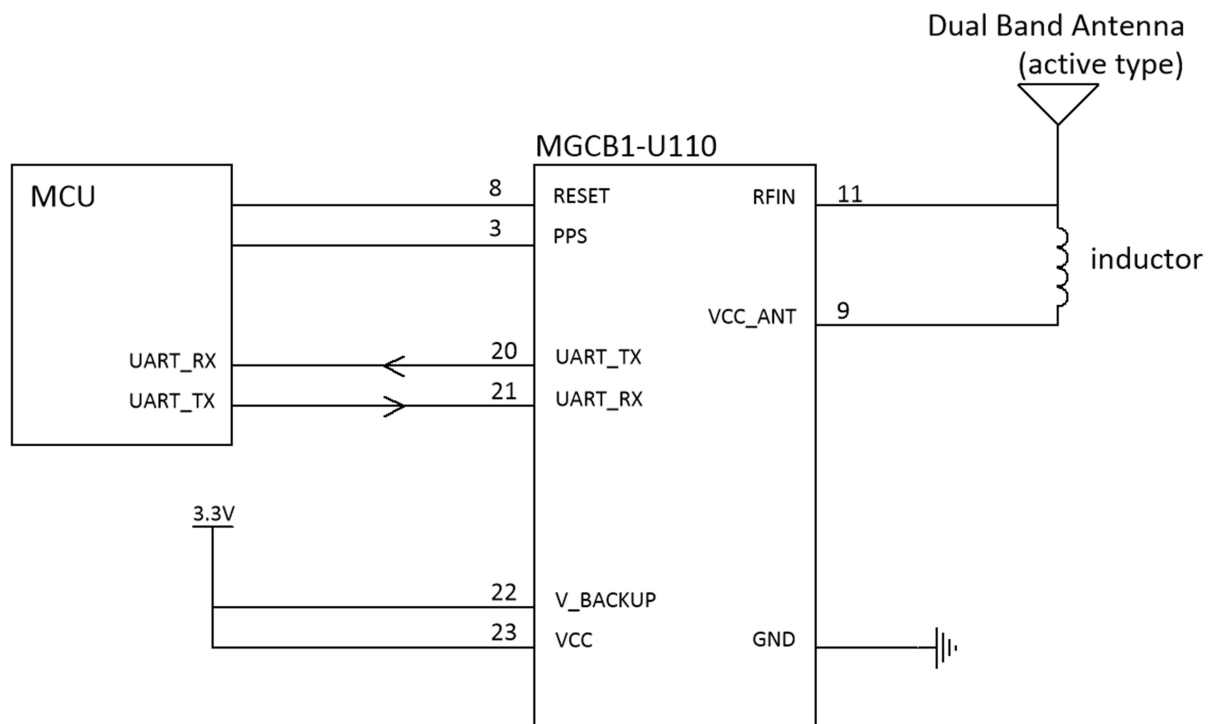

4. Pin Configuration and Function

4.1 Pin Configuration (Top View)

GND	<input type="checkbox"/>	13	12	<input type="checkbox"/>	GND
NC	<input type="checkbox"/>	14	11	<input type="checkbox"/>	RFIN
NC	<input type="checkbox"/>	15	10	<input type="checkbox"/>	GND
NC	<input type="checkbox"/>	16	9	<input type="checkbox"/>	VCC_ANT
NC	<input type="checkbox"/>	17	8	<input type="checkbox"/>	RESET
NC	<input type="checkbox"/>	18	7	<input type="checkbox"/>	NC
NC	<input type="checkbox"/>	19	6	<input type="checkbox"/>	NC
UART_TX	<input type="checkbox"/>	20	5	<input type="checkbox"/>	NC
UART_RX	<input type="checkbox"/>	21	4	<input type="checkbox"/>	NC
V_BACKUP	<input type="checkbox"/>	22	3	<input type="checkbox"/>	PPS
VCC	<input type="checkbox"/>	23	2	<input type="checkbox"/>	NOTIFY
GND	<input type="checkbox"/>	24	1	<input type="checkbox"/>	WAKE_UP

4.2 Pin Function

PIN		Type	Description
Number	Name		
1	WAKEUP	I	Host wakeup GNSS module. Wake-up module from stand-by mode. Low active. Open this pin, if no uses this function. 1.8V level
2	NOTIFY	O	GNSS module notify host. High active. Open this pin, if no uses this function. 1.8V level
3	PPS	O	1PPS signal, 1.8V level
8	RESET	O	Reset, internal pull-high. Low active,1.8V level
9	VCC_ANT	P	Voltage Supply for external active antenna
11	RFIN	I	RF input, internal DC block
20	UART_TX	O	UART transmit, 1.8V level
21	UART_RX	I	UART receive, 1.8V level
22	V_BACKUP	P	Backup Voltage supply
23	VCC	P	Voltage supply
10, 12, 13, 24	GND	GND	Ground pin. Connect to system ground
4, 5, 6, 7, 14, 15, 16, 17, 18, 19	NC	NC	No connect to internal circuit. Can be float.

5. Performance

5.1 RF performance

Parameter	Specifications
L1 Frequency (MHz)	GPS: L1 C/A, 1575.42 GLONASS: L1, 1603.68 Galileo: E1,1575.42 BeiDou: B1, 1561.098 QZSS: L1, 1575.42
L5 Frequency (MHz)	GPS: L5 , 1176.45 Galileo: E5, 1176.45 BeiDou: B2, 1176.45 QZSS: L5, 1176.45
L1 Channel	75
L5 Channel	60
Timing Accuracy	1pps, +/-10ns
Update rate	1Hz
Sensitivity	Tracking: -162 dBm Acquisition: -145 dBm
TTF	Hot start: 1 sec Cold start: 25 sec
Position Precision (CEP)	1 m
Max input level	-40dBm

5.2 Digital performance

Parameter	Specifications
Update rate	1Hz
UART	9600 bps
Protocols	NMEA 0183

6. Application

6.1 with passive antenna

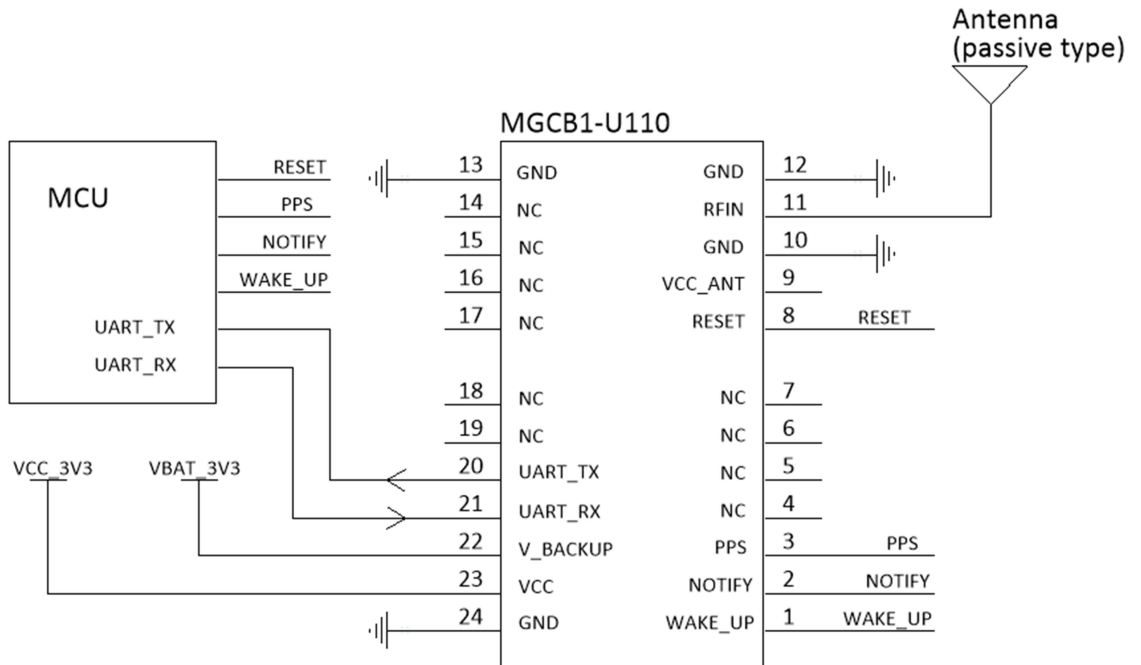

6.2 with active antenna

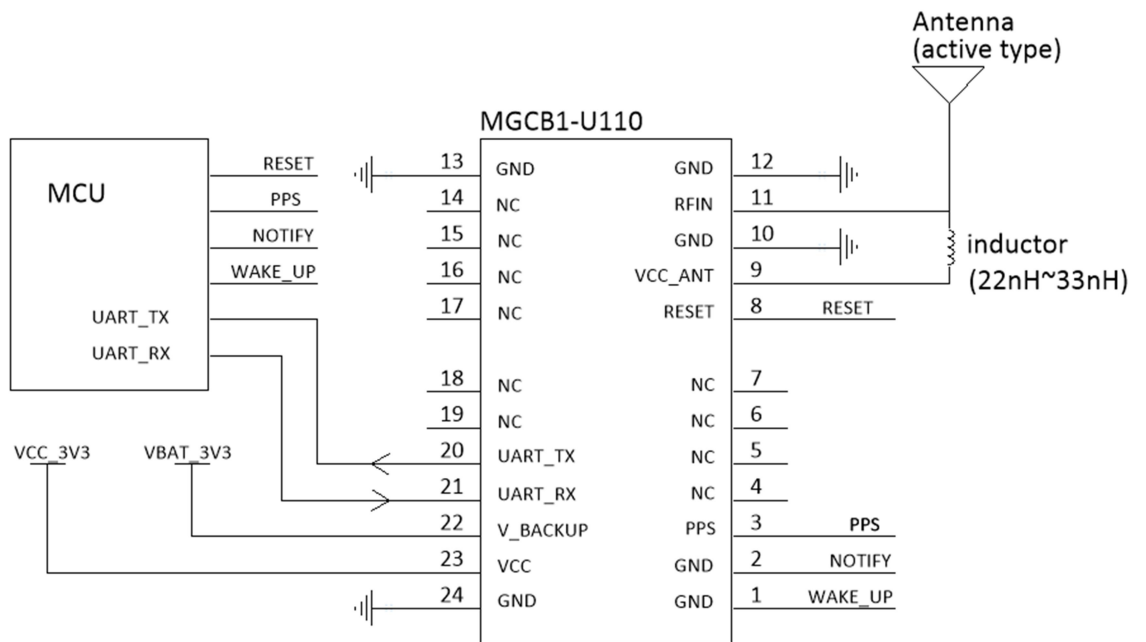

7. Electrical Specification

7.1 Absolution Rating

Parameter	Description	Min	Max	Unit
VCC	Voltage input		5.5	V
V_BACKUP	Backup voltage input		5.5	V
RF_IN	Max RF input level		-40	dBm

7.2 ESD Rating

Mode	JEDEC Specification	Min	Max	Unit
Human body model	JESD22-A114-F	-2000	2000	V
Charge device model	JESD22-C101-D	-500	500	V

7.3 Recommended Operation Conditions

Parameter	Description	Min	Max	Unit
VCC	Voltage input	3	5	V
V_BACKUP	Backup voltage input	3	5	V
V-IH	IO, UART	1.2	2.1	V
V-IL	IO, UART	-0.3	0.6	V
V-OH	IO, UART	1.4		V
V-OL	IO, UART		0.4	V
Temp-op	Operation temperature	-40	+85	°C
Temp-st	Storage temperature	-40	+105	°C

7.4 Power consumption

Parameter	Description	typical	Unit
Pcon	Power consumption	180	mW

8. Mechanical Specification

8.1 Outline Dimensions

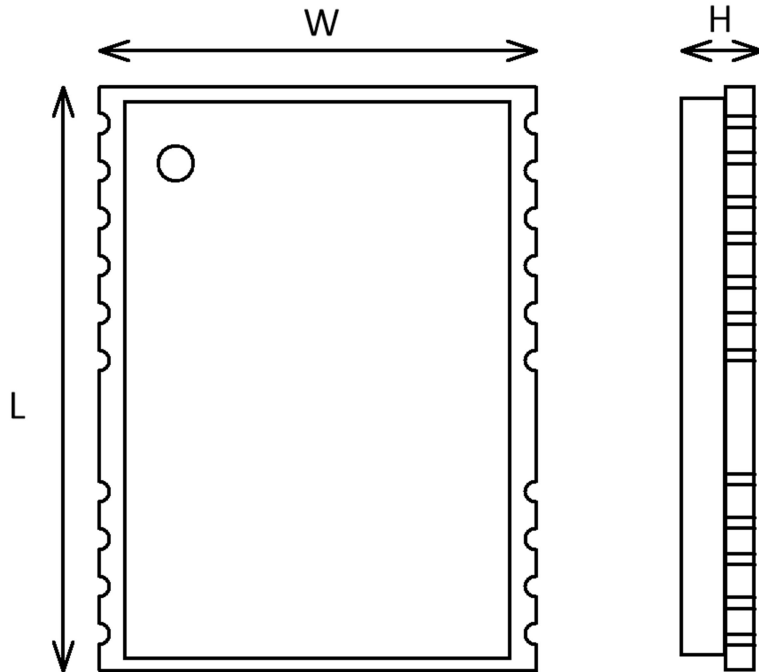

Symbol	Min (mm)	Normal (mm)	Max (mm)
W	12.0	12.2	12.4
L	15.8	16.0	16.2
H	2.3	2.5	2.7

8.2 PCB land pattern dimensions

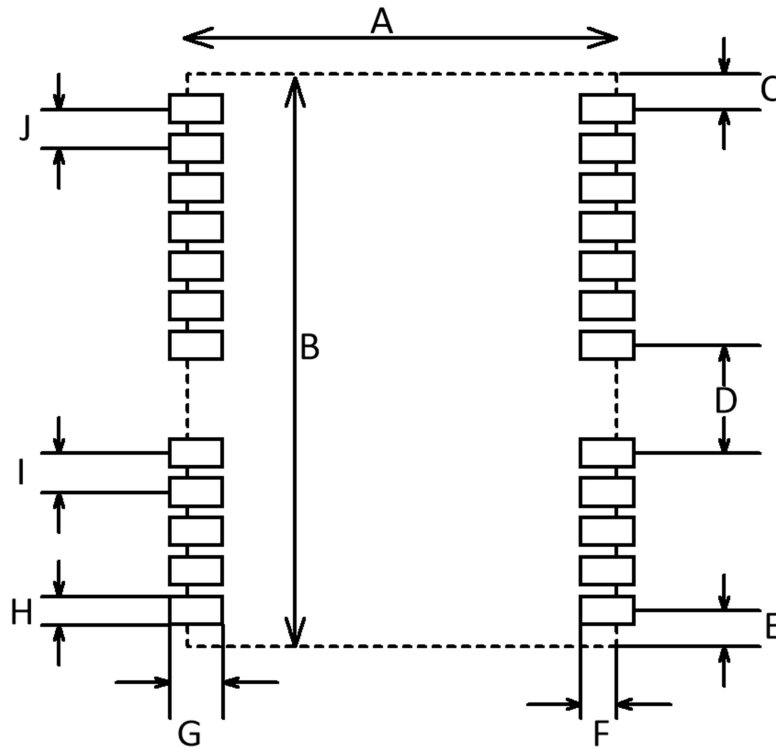

Symbol	Min (mm)	Normal (mm)	Max (mm)
A	12.0	12.2	12.4
B	15.8	16.0	16.2
C	0.9	1.0	1.1
D	2.9	3.0	3.1
E	0.9	1.0	1.1
F	0.5	0.6	0.7
G	0.7	0.8	0.9
H	0.7	0.8	0.9
I	1.0	1.1	1.2
J	1.0	1.1	1.2

9. Ordering Information

9.1 Ordering Information

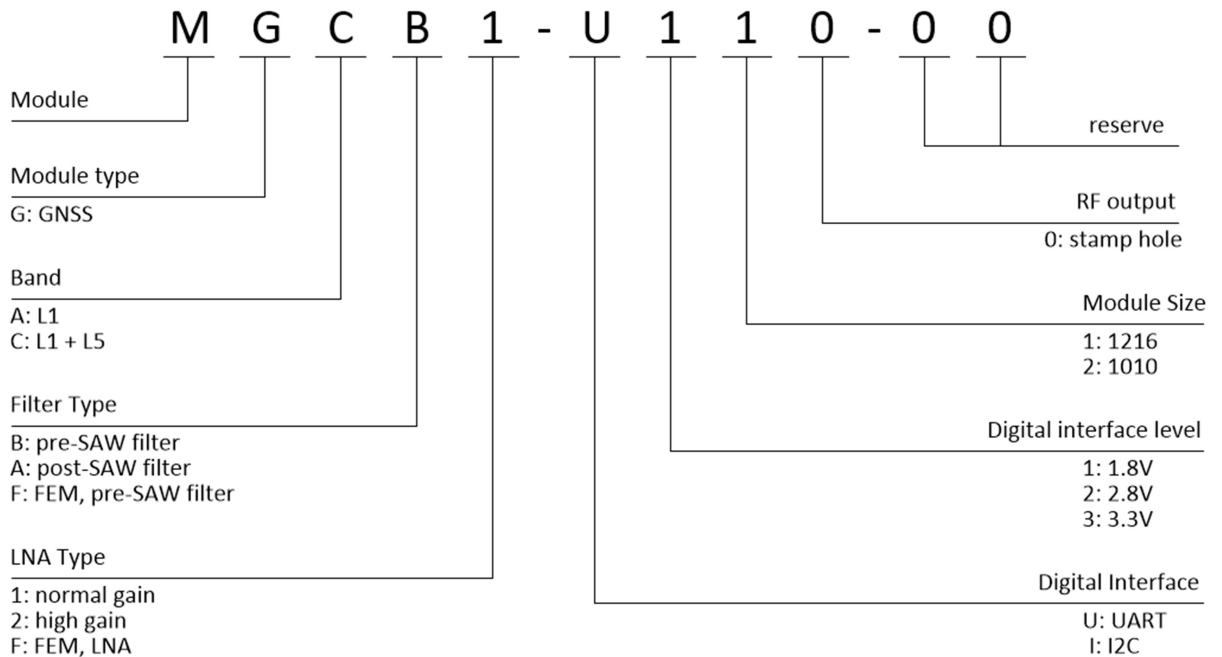

Part Number	Description
MGCB1-U110-00	1612 SMD type module
MGCB1-U110-EV	Evaluation Board

10. INPAQ relative and peripheral product

Series	Part Number	Description
GNSS receiver module	MGCB1-U110-00	normal gain GNSS receiver module
GNSS patch antenna	*	Active patch antenna
GNSS patch antenna	*	Passive patch antenna

Note:

* connect with INPAQ sales for more detail product information

11. Manufacturing

11.1 Reflow Soldering Thermal Profile

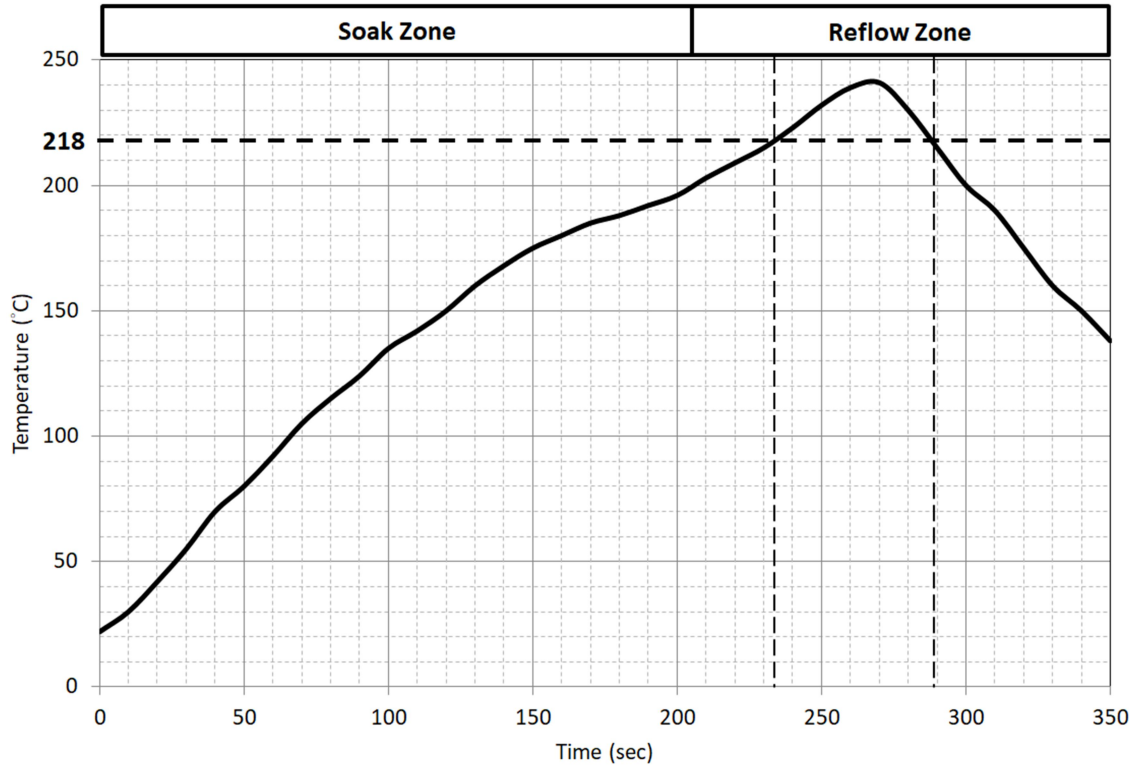

11.2 Thermal profile parameter

Zone	Factor	Description
Soak Zone	Max slope	3°C/sec
	Soak time (150°C ~ 200°C)	60 sec ~120 sec
Reflow Zone	Max slope	2°C/sec
	Soak time (over 220°C)	40 sec ~60 sec
	Max temperature	245°C
	Cooling down slope	-1°C/sec to -3°C/sec
Reflow cycle	Max reflow cycle	1

12. Version

Version	Date	Description
V0.1	2024.02.26	Initial release
V0.2	2024.12.19	Add CE/RED certification (ETSI EN 303 413)