

### ◆ Feature

- 1.High gain
- 2.Customization available
- 3.Pin type
- 4.Compact size and low profile
- 5.RoHS compliant



### ◆ Application

Automobile, Marine, Aviation, Handheld Device



### ◆ Dimension (mm): 18.4×18.4×2

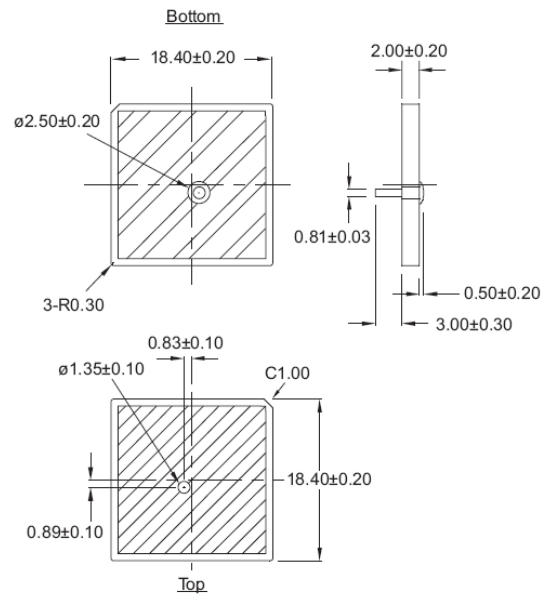

### ◆ Specification

Center Frequency (MHz)	1580±2
Bandwidth (MHz)	7.0 min.
Gain at Zenith (dBic)	1.0 typ.
Gain at 10° Elevation (dBic)	-5.5 typ.
Polarization	R.H.C.P.
Impedance (Ω)	50 typ.
Frequency Temperature Coefficient (ppm/°C)	0±20
Axial Ratio (dB)	≤ 3
Testing Condition	J Type: 50 mm Square Ground Plane
Package	J type: 50 pcs/tray