

◆ Feature

- 1.Linear polarization
- 2.Omni-directional
- 3.Compact size
- 4.RoHS compliant



◆ Application

Automobile, Marine, Aviation, Handheld Device



◆ Dimension (mm): 20.2x6x3.8

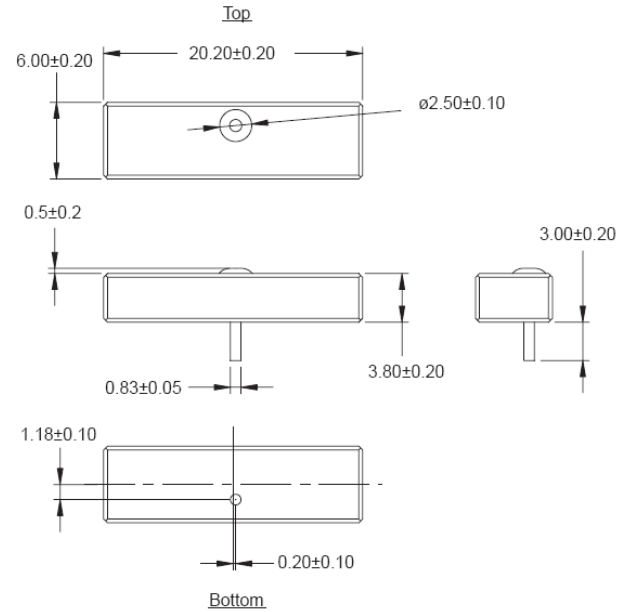

◆ Specification

Center Frequency (MHz)	1575.42±2.5
Bandwidth (MHz)	6.0 min.
Gain at Zenith (dBic)	-0.5 (dBi) typ.
Gain at 10° elevation (dBic)	—
Polarization	L.P.
Impedance (Ω)	50 typ.
Frequency Temperature Coefficient (ppm/°C)	0±20
Axial Ratio (dB)	—
Testing Condition	K Type: 30 ×10 mm Ground Plane
Package	50 pcs/tray