

RoHS



## MLVS0201 Series Engineering Specification

### 1. Scope

- (1) SMD type zinc oxide based ceramic chip
- (2) Lead free plating termination provided good solderability characteristic
- (3) Insulator over coat keeps excellent low and stable leakage current
- (4) Quick response time (<1ns)
- (5) Low clamping voltage
- (6) High transient current capability
- (7) Meet IEC 61000-4-2 standard
- (8) Compact size for ELA 0201

### Applications

**Applications** for Mother Board and Notebook, Cellular Phone, PDA, handheld device, DSC, DV, Scanner, and Set-Top Box etc.

**Suitable** for Push-Button, Power Line and Low Frequency single line over voltage protect.

### 2. Explanation of Part Number

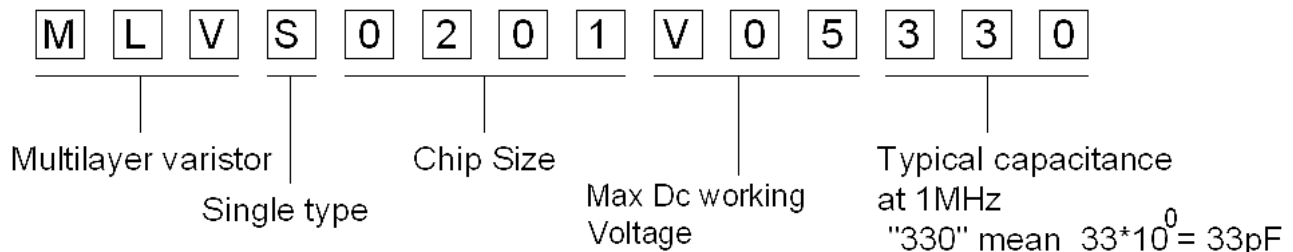

### 3. Construction & Dimension

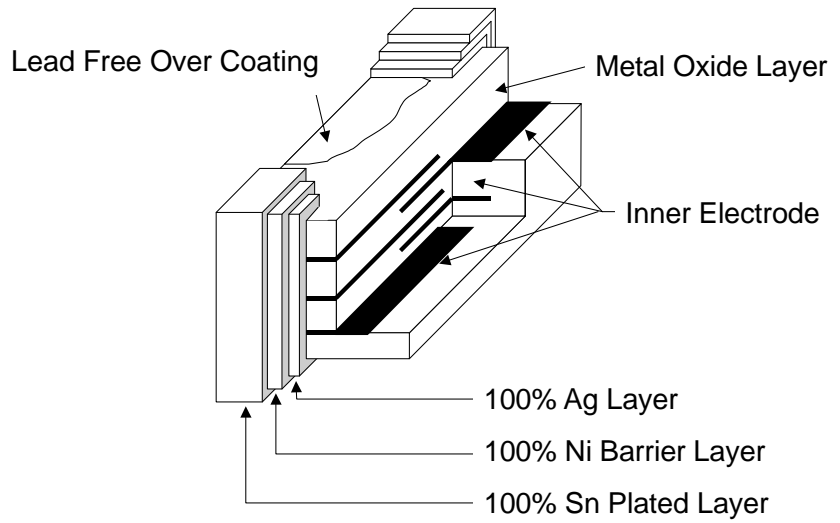
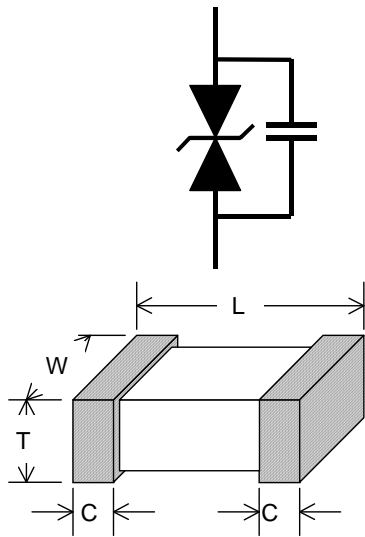

Unit: mm	0201
L	0.60±0.05
W	0.30±0.05
T	0.30±0.05
C	0.20±0.10

### 4. Part ratings

#### 4.1. Rating(25±5°C)

Symbol	Working voltage		Varistor voltage		Clamping Voltage	Capacitance	Peak current	Transient energy
	$V_{RMS}$	$V_{DC}$	$V_V$	$\Delta V_V$	$V_c$	$C_p$	$i_{max}$	$W_{max}$
Units	Volts	Volts (Max.)	Volts	%	Volts (Max.)	pF (Typical)	Amps (Max.)	Joules (Max.)
Test Condition		< 10 $\mu$ A	1mA DC		1 A 8/20 $\mu$ s	1MHz	8/20 $\mu$ s	10/1000 $\mu$ s
MLVS0201V05330	4	5.5	11	±3	28	33	-	-

$V_{RMS}$  – Maximum AC operating voltage the varistor can maintain and not exceed 10 $\mu$ A leakage current

$V_{DC}$  – Maximum DC operating voltage the varistor can maintain and not exceed 10 $\mu$ A leakage current

$V_V$  –Voltage across the device measured at 1mA DC current.  
EquiValent to  $V_b$ , “Breakdown Voltage”.

$V_c$  – Maximum peak voltage across the varistor measured at 8/20us waveform and 1A pulse current

$C_p$  – Device capacitance measured with zero volt bias 1Vrms at 1MHz.  
Capacitance Tolerance: M= $\pm$ 20% , K= $\pm$ 10%.

$i_{max}$  – Maximum peak current which may be applied with 8/20us waveform without device failure

$W_{max}$  – Maximum energy that may be dissipated with the 10/1000us waveform without device failure

## 5. General electrical specifications

### 5.1. General technical data

Operating temperature	-40 $^{\circ}$ C ~ +85 $^{\circ}$ C
Storage temperature (on board)	-40 $^{\circ}$ C ~ +85 $^{\circ}$ C
Response time	<1 ns
Solderability	245 $\pm$ 5 $^{\circ}$ C, 3 $\pm$ 1sec.
Solder leach resistance	260 $\pm$ 5 $^{\circ}$ C, 10 $\pm$ 1sec.

### 5.2 Environmental Specifications

Characteristics	Specifications	Test condition
Bias humidity	$\Delta V_V / V_V \leq \pm 10\%$	90%RH, 40 $^{\circ}$ C, Working voltage, 1000 hours
Thermal shock	$\Delta V_V / V_V \leq \pm 10\%$	-40 $^{\circ}$ C to 85 $^{\circ}$ C, 30 min. Cycle, 5 cycles
Full load voltage	$\Delta V_V / V_V \leq \pm 10\%$	Working voltage, 85 $^{\circ}$ C, 1000 hours

### 5.3. Storage Condition with package

Storage Time: 12 months max

Storage Temperature : 5 to 40 $^{\circ}$ C

Relative Humidity: to 65 %

## 6. Taping Package and Label Marking

### 6.1. Packaging method

Products shall be heat-sealed in the chip pocket; spacing pitch 4-mm of plastic carrier tape with cover tape, and the carrier tape shall be reeled to the reel.

### 6.2. Carrier tape dimensions

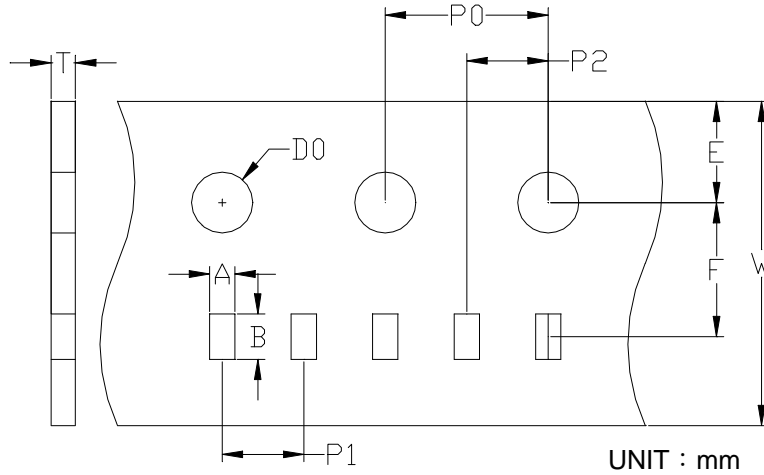

Type	A	B	W	E	F	P0	P1	P2	D0	T
0201	0.36 ±0.02	0.70 ±0.02	8.0 ±0.1	1.75 ±0.05	3.5 ±0.05	4.0 ±0.1	2.0 ±0.05	2.0 ±0.05	1.55 ±0.05	0.42 ±0.02

### 6.3. Taping reel dimensions

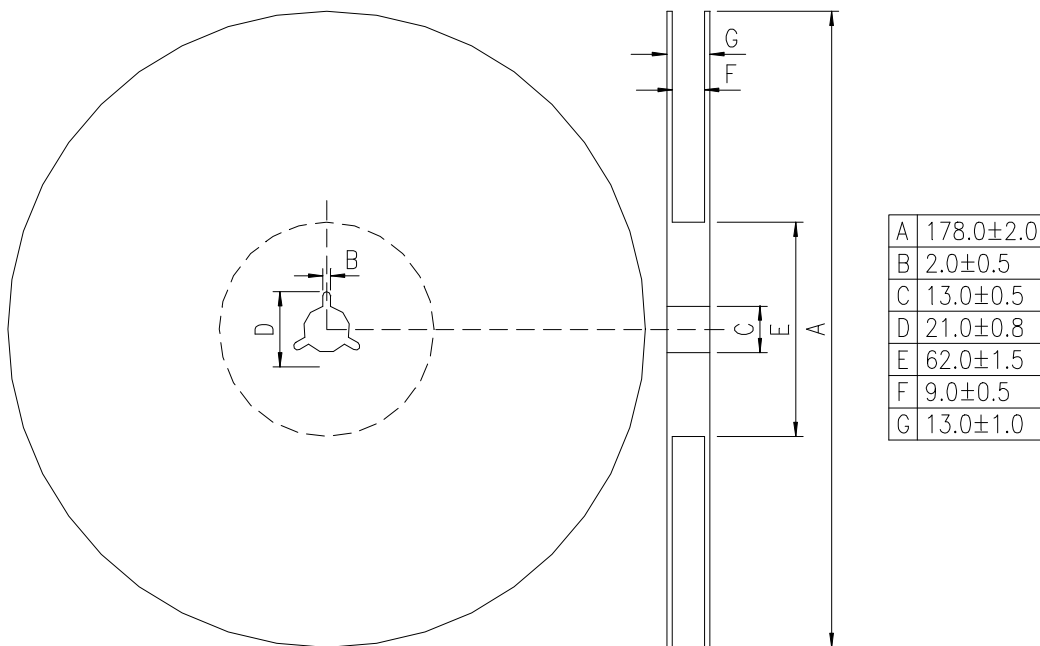

**6.4 Taping specifications**

There shall be the portion having no product in both the head and the end of taping, and there shall be the cover tape in the head of taping.

**6.5. Label Marking**

The label specified as follows shall be put on the side of reel.

- (1) Part No.
- (2) Quantity
- (3) Lot No.

\*Part No. And Quantity shall be marked on outer packaging.

**6.6. Quantity of products in the taping package**

- (1) Standard quantity : 15,000pcs/Reel for MLVS0201Series
- (2) Shipping quantity is a multiple of standard quantity.

**7. Precautions for Handling**

**7.1. Solder cream in reflow soldering**

Refer to the recommendable land pattern as printing mask pattern for solder cream.

0201

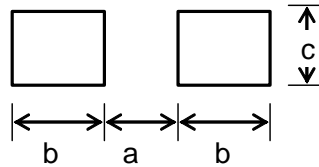

**Dimensions in mm**

Type	a	b	c
0201	0.4±0.1	0.5±0.05	0.5±0.1

**7.2. Precaution for handling of substrate**

Do not exceed to bend the board after soldering this product extremely.

(Reference examples)

- Mounting place must be as far as possible from the position, which is close to the break line of board, or on the line of large holes of board.
- Do not bend extremely the board, in mounting another components.  
If necessary, use back-up pin (support pin) to prevent from bending extremely.
- Do not break the board by hand. We recommend using the machine or the jig to break it.

**7.3. Precaution for soldering**

Note that rapid heating, rapid cooling or local heating will easily damage this product. Do not give heat shock over 100°C in the process of soldering. We recommend taking preheating and gradual cooling.

**7.4. Recommendable reflow soldering**

Profile Feature	Pb-Free Assembly
Average Ramp-Up Rate (T <sub>smax</sub> to T <sub>p</sub> )	3° C/second max.
<b>Preheat</b> – Temperature Min (T <sub>smin</sub> ) – Temperature Max (T <sub>smax</sub> ) – Time (t <sub>smin</sub> to t <sub>smax</sub> )	150 °C 200 °C 60-180 seconds
Time maintained above: – Temperature (T <sub>L</sub> ) – Time (t <sub>L</sub> )	217 °C 60-150 seconds
Peak/Classification Temperature (T <sub>p</sub> )	260 °C
Time within 5 °C of actual Peak Temperature (t <sub>p</sub> )	20-40 seconds
Ramp-Down Rate	6 °C/second max.
Time 25 °C to Peak Temperature	8 minutes max.

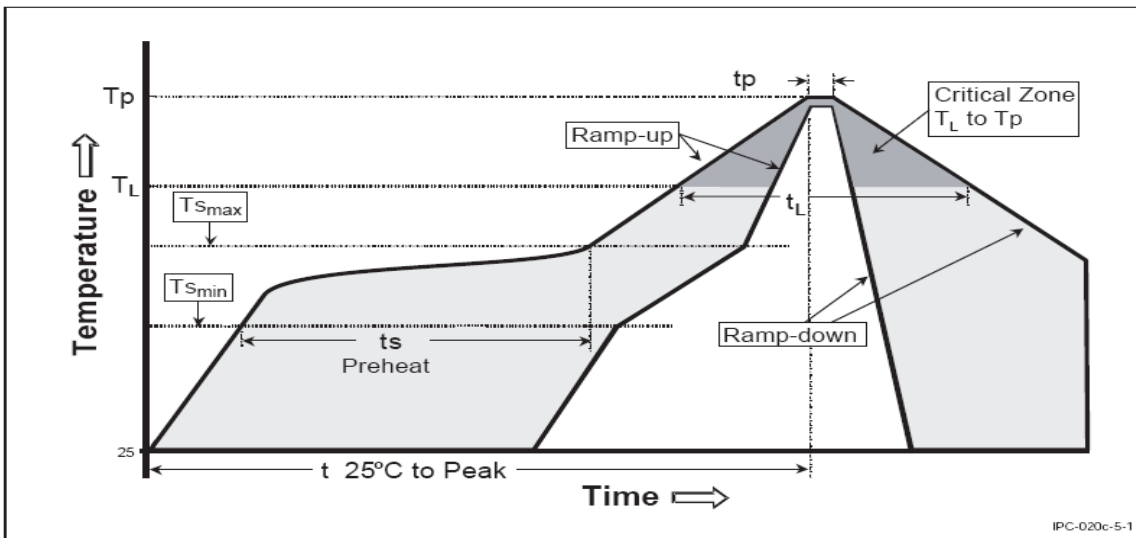

\*Areference: J-STD-020C

### 7.5. Soldering gun procedure

Note the follows, in case of using solder gun for replacement.

- (1) The tip temperature must be less than 280°C for the period within 3 seconds by using soldering gun less than 30 W.
- (2) The soldering gun tip shall not touch this product directly.

### 7.6. Soldering volume

Note that excess of soldering volume will easily get crack the body of this product.