



Chip Ferrite Bead (MCB-S Series) Engineering Spec.

■ PRODUCT DETAIL

Electrical Characteristics			Test Instruments
Z	Ω (Ref. Page 6~8)	TEST FREQ: (Ref. Page 6~8)MHz	●HP4291B RF IMPEDANCE / MATERIAL ANALYZER ●HP4338A/B MILLIOHMMETER ●Agilent 8720ES S-PARAMETER NETWORK ANALYZER ●HP6632B SYSTEM DC POWER SUPPLY
DCR	Ω (Ref. Page 6~8)	TEST LEVEL: 250 mV	
IDC	mA (Ref. Page 6~8)		

■ SHAPES AND DIMENSIONS

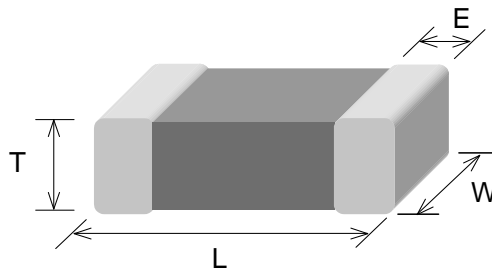

Unit: mm

TYPE	1005 (EIA 0402)	1608 (EIA 0603)	2012 (EIA 0805)	3216 (EIA 1206)	3225 (EIA 1210)	4516 (EIA 1806)	4532 (EIA 1812)
L	1.00±0.10	1.60±0.15	2.00±0.20	3.20±0.20	3.20±0.20	4.50±0.25	4.50±0.25
W	0.50±0.10	0.80±0.15	1.25±0.20	1.60±0.20	2.50±0.20	1.60±0.20	3.20±0.25
T	0.50±0.10	0.80±0.15	0.90±0.20	1.10±0.20	1.30±0.20	1.60±0.20	1.50±0.25
E	0.25±0.10	0.30±0.20	0.50±0.30	0.50±0.30	0.50±0.30	0.60±0.40	0.60±0.40

■ PART NUMBER CODE

MCB 1608 S 60 1 E B P
 1 2 3 4 5 6 7 8

- 1 Series Name
- 2 Size Code: the first two digitals : length(mm), the last two digitals : width(mm)
- 3 Material Code
- 4 Impedance(Ω) $\pm 25\%$ } (ex : 600=60 Ω ; 121=120 Ω)
- 5 Fixed Decimal Point
- 6 Rated Current Code

A=50mA	B=80mA	C=100mA	D=150mA	E=200mA	F=300mA
G=400mA	H=500mA	I=600mA	J=700mA	K=800mA	

- 7 Soldering : Green Parts: A— Soldering Lead-Free B— Lead-Free for whole chip
- 8 Packaging: P - Embossed paper tape, 7" reel.
E - Embossed plastic tape, 7" reel.

■ TAPE AND REEL SPECIFICATIONS
PLASTIC CARRIER

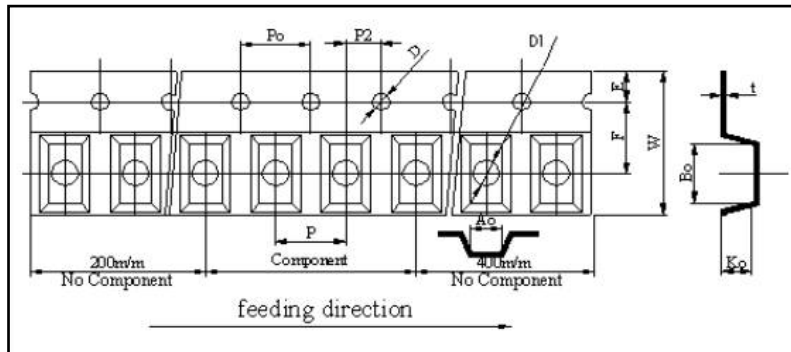

PAPER CARRIER

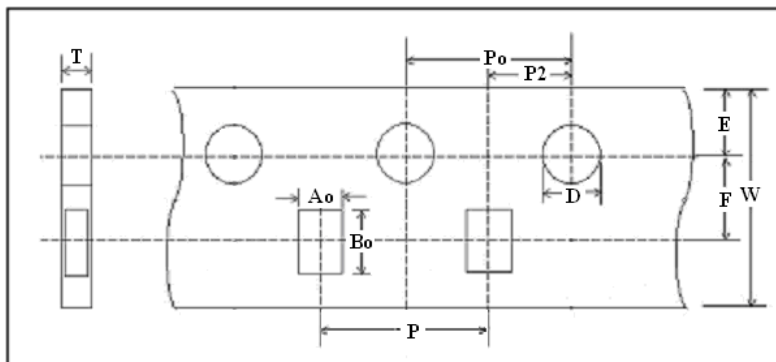

■ TAPING DIMENSIONS

Unit: mm

Size	4532	4516	3225	3216	2012	1608	1005
Symbol	PLASTIC	PLASTIC	PLASTIC	PLASTIC	PAPER	PAPER	PAPER
W	12.0±0.10	11.7~12.3	7.70~8.30	7.90~8.30	8.00±0.10	8.00±0.10	8.00±0.10
P	8.00±0.10	4.00±0.10	4.00±0.10	4.00±0.10	4.00±0.10	4.00±0.10	2.00±0.05
E	1.75±0.10	1.75±0.10	1.75±0.10	1.75±0.10	1.75±0.10	1.75±0.10	1.75±0.05
F	5.50±0.05	5.50±0.05	3.50±0.05	3.50±0.05	3.50±0.10	3.50±0.10	3.50±0.05
D	1.55±0.05	1.55±0.05	1.55±0.05	1.55±0.05	1.56±0.10	1.56±0.10	1.55±0.05
D1	1.50~1.75	1.50~1.75	0.95~1.20	0.95~1.20	NA	NA	NA
Po	4.00±0.10	4.00±0.10	4.00±0.10	4.00±0.10	4.00±0.10	4.00±0.10	4.00±0.10
Po10	40.0±0.20	40.0±0.20	40.0±0.20	40.0±0.20	40.0±0.20	NA	NA
P2	2.00±0.05	2.00±0.05	2.00±0.05	2.00±0.05	2.00±0.10	2.00±0.10	2.00±0.05
Ao	3.66±0.10	1.83±0.10	2.57±0.10	1.85±0.10	1.50±0.05	1.05±0.05	0.62±0.03
Bo	4.95±0.10	4.85±0.10	3.40±0.10	3.43±0.10	2.30±0.05	1.85±0.05	1.12±0.03
Ko(T)	1.83±0.10	1.83±0.10	1.32±0.10	1.22±0.10	0.95±0.05	0.95±0.05	0.60±0.03
t	0.23±0.10	0.29±0.10	0.25±0.10	0.25±0.10	NA	NA	NA

■ REEL DIMENSIONS

Unit: mm

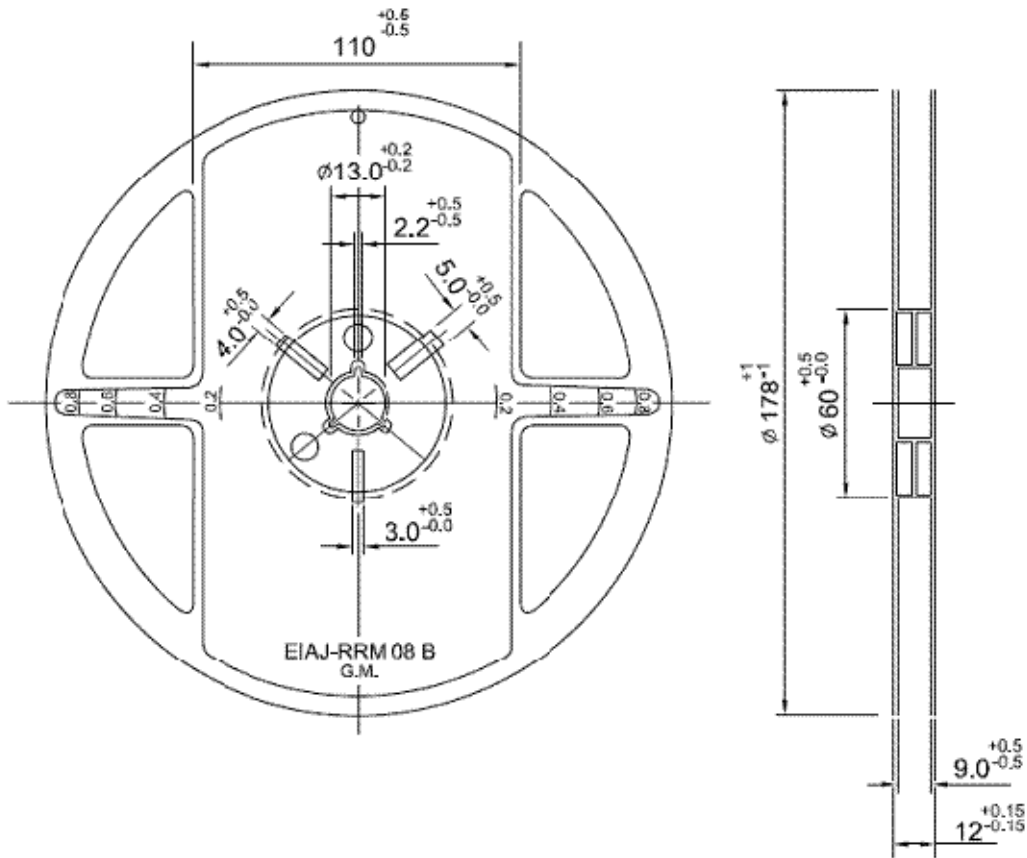

Reel Packaging Quantity								
PART SIZE (EIA SIZE)		1005 (0402)	1608 (0603)	2012 (0805)	3216 (1206)	3225 (1210)	4516 (1806)	4532 (1812)
7" REEL	Qty. (pcs)	10,000	4,000	4,000	3,000	2,000	2,000	1,000

The Contents of a box :

- 4532 (1812): 4 reels / inner box ;
- 4516 (1806): 4 reels / inner box ;
- 3225 (1210): 5 reels / inner box ;
- 3216 (1206): 5 reels / inner box ;
- 2012 (0805): 5 reels / inner box ;
- 1608 (0603): 5 reels / inner box ;
- 1005 (0402): 5 reels / inner box .

RECOMMENDED SOLDERING CONDITIONS

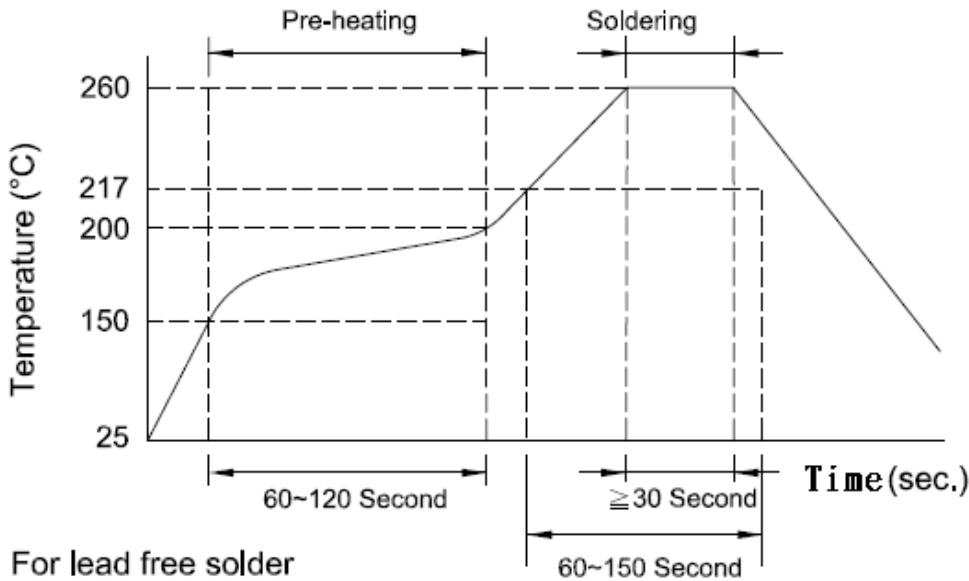

LAND PATTERNS FOR REFLOW SOLDERING

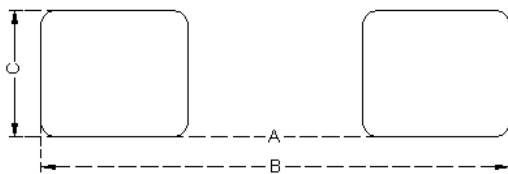

SOLDER LAND INFORMATION

Unit: mm (inches)

Size	A	B	C
1005	0.4 ~ 0.6 (0.015 ~ 0.023)	1.6 ~ 2.6 (0.063 ~ 0.102)	0.4 ~ 0.7 (0.016 ~ 0.027)
1608	0.5 ~ 0.7 (0.019 ~ 0.027)	2.1 ~ 3.1 (0.083 ~ 0.122)	0.65 ~ 0.95 (0.026 ~ 0.037)
2012	1.0 ~ 1.2 (0.039 ~ 0.047)	3.0 ~ 4.0 (0.118 ~ 0.157)	0.8 ~ 1.1 (0.031 ~ 0.043)
3216	2.0 ~ 2.4 (0.079 ~ 0.094)	4.2 ~ 5.2 (0.165 ~ 0.204)	1.0 ~ 1.4 (0.039 ~ 0.055)
3225	2.1 ~ 2.3 (0.082 ~ 0.090)	4.2 ~ 5.2 (0.165 ~ 0.204)	2.2 ~ 2.5 (0.086 ~ 0.098)
4516	3.4 ~ 3.7 (0.133 ~ 0.145)	6.3 ~ 7.3 (0.248 ~ 0.287)	1.3 ~ 1.7 (0.051 ~ 0.067)
4532	3.4 ~ 3.7 (0.133 ~ 0.145)	6.3 ~ 7.3 (0.248 ~ 0.287)	2.9 ~ 3.2 (0.144 ~ 0.126)

■ RELIABILITY AND TEST CONDITION

Test item	Test condition	Criteria
Temperature Cycle	a. Temperature : -40 ~ +85°C b. Cycle : 100 cycles c. Dwell time : 30minutes d. Measurement : at ambient temperature 24 hrs after test completion	a. No mechanical damage b. Impedance value should be within $\pm 20\%$ of the initial value
Operational Life	a. Temperature : 125°C \pm 5°C b. Test time : 1000 hrs c. Apply current : full rated current d. Measurement : at ambient temperature 24 hrs after test completion	a. No mechanical damage b. Impedance value should be within $\pm 20\%$ of the initial value
Biased Humidity	a. Temperature : 40°C \pm 2°C b. Humidity : 90 ~ 95 % RH c. Test time : 1000 hrs d. Apply current : full rated current e. Measurement : at ambient temperature 24 hrs after test completion	a. No mechanical damage b. Impedance value should be within $\pm 20\%$ of the initial value
Resistance to Solder Heat	a. Solder temperature : 260 \pm 5°C b. Flux : Rosin c. DIP time : 10 \pm 1 sec	a. More than 95 % of terminal electrode should be covered with new solder b. No mechanical damage c. Impedance value should be within $\pm 20\%$ of the initial value
Adhesive Test	a. Reflow temperature : 245°C It shall be Soldered on the substrate applying direction parallel to the substrate b. Apply force(F) : 5 N c. Test time : 10 sec	a. No mechanical damage b. Soldering the products on PCB after the pulling test force > 5 N

Test item	Test condition	Criteria
Steam Aging Test	a. Temperature : 93°C b. Test time : 4 hrs(MCB1005) Others : 8 hrs c. Solder temperature : 235 ± 5°C d. Flux : Rosin e. DIP time : 5 ± 1 sec	More than 95 % of terminal electrode should be covered with new solder
Rated Current Test	a. Apply current : full rated current / 5min	Temperature rise should be less than 25°C

■ GENERAL TECHNICAL DATA

Operating temperature range : - 55°C ~ +125°C

Storage Condition : Less than 40°C and 70% RH

Storage Time: 6 months(Size:1005)

12 months(Size:1608 above)

Soldering method: Reflow or Wave Soldering

■ PART NUMBER AND CHARACTERISTICS TABLE

Part No.	Impedance(Ω) +/-25%	Test Freq.(MHz)	DCR(Ω) (Max.)	Rated Current (mA)
MCB1005-S Series				
MCB1005S100FB_	10	100	0.10	300
MCB1005S200FB_	20	100	0.20	300
MCB1005S300FB_	30	100	0.25	300
MCB1005S400FB_	40	100	0.30	300
MCB1005S600FB_	60	100	0.35	300
MCB1005S700FB_	70	100	0.35	300
MCB1005S121FB_	120	100	0.40	300
MCB1005S241EB_	240	100	0.70	200
MCB1005S301EB_	300	100	0.80	200
MCB1005S471EB_	470	100	1.00	200
MCB1005S601FB_	600	100	1.00	300
MCB1005S102EB_	1000	100	1.50	200

Part No.	Impedance(Ω) +/-25%	Test Freq.(MHz)	DCR(Ω) (Max.)	Rated Current (mA)
MCB1608-S Series				
MCB1608S100IB_	10	100	0.05	600
MCB1608S220IB_	22	100	0.05	600
MCB1608S300IB_	30	100	0.08	600
MCB1608S400IB_	40	100	0.10	600
MCB1608S600IB_	60	100	0.10	600
MCB1608S700IB_	70	100	0.10	600
MCB1608S800IB_	80	100	0.10	600
MCB1608S101IB_	100	100	0.15	600
MCB1608S121IB_	120	100	0.15	600
MCB1608S181FB_	180	100	0.30	300
MCB1608S221FB_	220	100	0.30	300
MCB1608S301FB_	300	100	0.35	300
MCB1608S471FB_	470	100	0.40	300
MCB1608S601EB_	600	100	0.45	200
MCB1608S751CB_	750	100	0.60	100
MCB1608S102CB_	1000	100	0.60	100
MCB2012-S Series				
MCB2012S070KB_	7	100	0.05	800
MCB2012S110KB_	11	100	0.05	800
MCB2012S170KB_	17	100	0.05	800
MCB2012S260KB_	26	100	0.05	800
MCB2012S300KB_	30	100	0.05	800
MCB2012S320KB_	32	100	0.05	800
MCB2012S400KB_	40	100	0.05	800
MCB2012S600KB_	60	100	0.15	800
MCB2012S800KB_	80	100	0.15	800
MCB2012S900KB_	90	100	0.15	800
MCB2012S121KB_	120	100	0.15	800
MCB2012S151KB_	150	100	0.15	800
MCB2012S181HB_	180	100	0.20	500
MCB2012S221HB_	220	100	0.20	500
MCB2012S301HB_	300	100	0.20	500
MCB2012S401HB_	400	100	0.30	500
MCB2012S601HB_	600	100	0.30	500
MCB2012S102FB_	1000	100	0.35	300
MCB2012S152FB_	1500	100	0.40	300
MCB2012S202EB_	2000	100	0.50	200

Part No.	Impedance(Ω) +/-25%	Test Freq.(MHz)	DCR(Ω) (Max.)	Rated Current (mA)
MCB3216-S Series				
MCB3216S190KB_	19	100	0.05	800
MCB3216S260KB_	26	100	0.05	800
MCB3216S310KB_	31	100	0.05	800
MCB3216S500KB_	50	100	0.08	800
MCB3216S700KB_	70	100	0.10	800
MCB3216S900KB_	90	100	0.15	800
MCB3216S121IB_	120	100	0.15	600
MCB3216S151IB_	150	100	0.15	600
MCB3216S201IB_	200	100	0.20	600
MCB3216S221IB_	220	100	0.20	600
MCB3216S301IB_	300	100	0.20	600
MCB3216S601HB_	600	100	0.30	500
MCB3216S102HB_	1000	100	0.40	500
MCB3216S122HB_	1200	100	0.40	500
MCB3216S152EB_	1500	50	0.50	200
MCB3216S202EB_	2000	30	0.50	200
MCB3225-S Series				
MCB3225S310KB_	31	100	0.30	800
MCB3225S600KB_	60	100	0.30	800
MCB3225S900KB_	90	100	0.30	800
MCB4516-S Series				
MCB4516S680KB_	68	100	0.10	800
MCB4516S800KB_	80	100	0.10	800
MCB4516S101KB_	100	100	0.20	800
MCB4516S151KB_	150	100	0.30	800
MCB4532-S Series				
MCB4532S700KB_	70	100	0.40	800
MCB4532S800KB_	80	100	0.40	800
MCB4532S121KB_	120	100	0.40	800

** For special part number which is not shown in the above table, please refer to appendix.

■ PART COMPOSITION DECLARATION

Composition part	Material Name	Element name composition	CAS No.	Substance Mass(mg)	
				mass(mg)	%
Ceramic body	Ferrite Powder	Fe	7439-89-6	2.7240	53.1%
		Cu	7440-50-8	0.0975	1.9%
		Ni	7440-02-0	0.7695	15.0%
		Zn	7440-66-6	0.8208	16.0%
	Silver Conductor	Ag	7440-22-4	0.3591	7.0%
	Internal Electrode	Ag	7440-22-4	0.2975	5.8%
Termination	Nickel Sulfamate	Ni	7440-02-0	0.0103	0.2%
External electrode	Solder	Sn	7440-31-5	0.0513	1.0%